

the essence of your success



# FS INPUT

the functional specification database powered by vogelbusch biopharma

# FS INPUT® the functional specification database



Flexible and modular structure following the current guidelines of ANSI/ISA-88



## Generate functional specification documents in a standardized and consistent way

**FS INPUT®** is a database tool for the creation of functional specification documents for process automation of batch operated biotechnological plants. **FS INPUT®** was developed to meet the high standards of GMP regulation in life science industry. It enables the user to generate functional specification documents in a standardized and consistent way. The flexible and modular structure of **FS INPUT®** follows the guidelines of ANSI/ISA-88 and allows the execution of various automation concepts used in large and complex projects.

## **FS INPUT®** – an engineering tool used for more than 10 years

As one of the world's leading suppliers of engineering for biotechnological plants, Vogelbusch Biopharma developed **FS INPUT®** to meet the high project requirements in terms of quality, timeline and documentation standards. Especially in the field of automation, the use of standard office software becomes impractical once a project exceeds a certain size and complexity. The need to guarantee consistent quality and to avoid repetitive work motivated us to develop **FS INPUT®**.

**FS INPUT®** has been used in many projects with various automation systems for more than 10 years. Continuous improvement and optimization resulted in a lean and efficient software with a focus on:

- Meeting the requirements of complex and large scale projects with hundreds of documents and thousands of automated valves
- Being independent of the selected automation system and supplier
- Support the total life cycle of functional specification documents - documents can be used for software coding, as test documents for qualification and for documentation of process optimization
- Saving time and costs by avoiding unnecessary tasks and workarounds



Designed to meet GMP requirements and to maintain consistency, independent of project scale

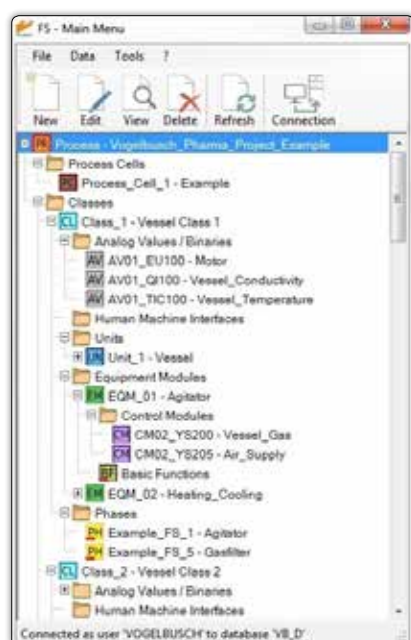

## Developed for large scale biotechnology plants

Biotechnology plants are highly complex systems in a strictly regulated environment. **FS INPUT**® is designed to generate documents that comply with the requirements of Good Manufacturing Practice (GMP).

The structure of **FS INPUT**® is made for handling big amounts of data required for complex and large scale projects. All areas of a biotechnological plant, e.g. media and buffer preparation, upstream, downstream and utility systems can be covered by one tool. Also special requirements of the biopharmaceutical industry, e.g. hygienic states can be specified and used in **FS INPUT**®.

Independent of the scale, **FS INPUT**® maintains the consistency and keeps track of all information. Due to the high standard of functional specification documents created in **FS INPUT**®, the effort for the subsequent generation of functional design specifications (FDS) can be reduced significantly.

**FS INPUT**® is designed to support engineering companies in the execution of individual automation projects of various sizes and degrees of complexity. Also large manufacturing companies can benefit from the tool as a central database for all production systems to maintain overview and to document process modifications and upgrades.

## Central data and revision management

In order to provide the highest level of data integrity, **FS INPUT**® stores all information in a central database. Efficiency is increased and workarounds are reduced, as data entry and modification only need to be made once and the current state of the project is accessible to all users at the same time.

We know that version control is an essential feature in engineering. In **FS INPUT**® each document has a unique revision number and editing state (e.g. “for review”, “for approval”...) as well as a detailed revision history. Earlier revisions are saved and can be viewed but no longer be manipulated in order to maintain integrity and traceability.

You can track all changes by a revision compare function. Differences between an earlier version and the current state of a functional specification can be viewed and compiled into a document.





## Avoid errors and reduce workload by referencing

In automation the approach of standardized building blocks ensures that similar systems work in a similar way. In **FS INPUT®** identical functions or functions with only minor differences can be defined once as a master function which includes all possible characteristics. Each reference of this master can easily be adapted by a replace function while changes in the master are replicated in all references.

Using this comprehensive system of referencing, **FS INPUT®** significantly reduces your workload, once a framework has been set up. The database minimizes the need to enter the same data into all documents individually and eliminates the resulting potential for errors.

Step	Pos	Master Description	Info	Used	Master Desc	Reference Description
100	1	Initiate		<input checked="" type="checkbox"/>	Initiate	Initiate
100	2	Acquire EQM		<input checked="" type="checkbox"/>	Acquire EQM	Acquire EQM
200	1	Heating HW		<input checked="" type="checkbox"/>	Heating HW	Heating HW
300	1	Heating 1		<input checked="" type="checkbox"/>	Heating 1	Heating 1
400	1	Heating 2		<input checked="" type="checkbox"/>	Heating 2	Heating 2
500	1	Sanitization		<input checked="" type="checkbox"/>	Sanitization	Sanitization
600	1	Heat temperature		<input checked="" type="checkbox"/>	Heat temperature	Heat temperature

Process	Class	Master Equipment Module	Process	Class	Reference	Equipment Module
Process	Class_M	EQM_H201 (Bottom_Group)	Process	Class_1	EQM_B001 (Bottom_Group)	
Process	Class_M	EQM_S001 (Gas_Supply)	Process	Class_1	EQM_G001 (Gas_Supply)	
Process	Class_M	EQM_H501 (Head_Group)	Process	Class_1	EQM_H501 (Head_Group)	
Process	Class_M	EQM_H501 (HPH_Supply)	Process	Class_1	EQM_H501 (HPH_Supply)	
Process	Class_M	EQM_T001 (Temperature_Control)	Process	Class_1	EQM_T001 (Temperature_Control)	
Process	Class_M	EQM_H501 (Head_Group)	Process	Class_1	EQM_H501 (Head_Group)	
Process	Class_M	EQM_H501 (HPH_Supply)	Process	Class_1	EQM_H501 (HPH_Supply)	

Efficient workflow due to master / reference system and multi user environment

## Data safety and user management

Know-how used in engineering and automation is often confidential intellectual property and always well protected. Therefore, **FS INPUT®** keeps all data on your in-house server which is secured by your safety system.

**FS INPUT®** is a multi-user system which includes several levels of access-rights. Warning messages and locks make sure that data is not changed by mistake and that each dataset is only edited by one user at the same time.



## Customer support at all levels

In the development of **FS INPUT**® a lot of effort was put into keeping it “easy to use”. Nevertheless the users of an engineering software need to become familiar with the tool as quickly as possible. Therefore, we offer training packages that cover all functions of **FS INPUT**® and enable you to achieve the best results right from the start.

With the experience from numerous projects our experts can help you to set up a project in **FS INPUT**®. Consulting and hands-on support is provided for either creating a new database or importing an existing project.

Also if you are already experienced in using **FS INPUT**® in your daily project work, you can rely on our assistance and benefit from a ticket-based online support system as well as an online knowledge database.



Optimized printout format of process steps and valve matrix according to your corporate design

## Customized document format

All information and details allocated to a certain process step (e.g. transfer, sterilization or cultivation) is edited via tailored user interfaces. **FS INPUT**® can compile the information into documents which can be used as functional specifications for software coding, qualification and process optimization.

While the user language of **FS INPUT**® is English, the project specific content of the functional specifications can also be generated in other languages. A batch printing function ensures consistent filenames and time-saving compilation of the documents.

As the valve matrix is one of the most important parts of a functional specification document, we optimized the printout format. A poster-sized valve matrix is split into folder-sized pages for easy handling. Intelligent spacing and pagination make sure that the valve matrix keeps its consistency.

The formal and content related details of functional specification documents can be customized according to your needs and your corporate design. Due to the high flexibility, **FS INPUT**® can be used for document preparation, regardless of your preferred automation supplier.

In addition to the functional specification documents, a variety of supplementary spreadsheets can be compiled in order to support efficient software coding.

Description of plant in a structured way - from process overview to individual valves and sensors

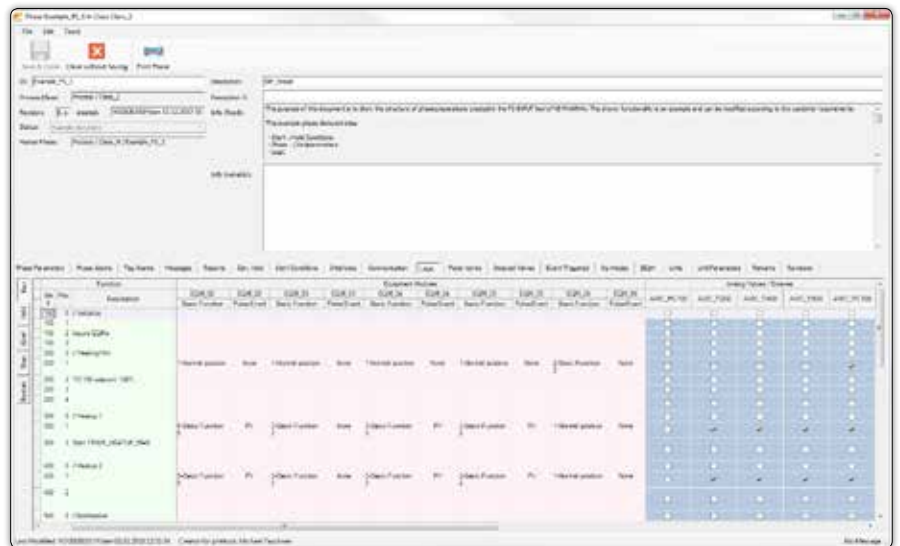

## Physical model in FS INPUT®

**FS INPUT®** follows the standard ANSI/ISA-88 Batch Control Part 1: Models and Terminology in the definition of the physical model of a biotechnological plant. The information in the physical model shows the structure of the process plant, including all vessels, actors and sensors as well as their tags.

**Process:** The process is the highest hierarchical level in the **FS INPUT®** database (e.g. an entire biotechnological production process) and gives an overview over parameters, transfer ways and hygienic states.

**Process Cell:** A section of a process plant that includes a full set of physical processing equipment is called a process cell (e.g. upstream or downstream).

**Class:** Several identical or similar units can be arranged within classes (e.g. all media tanks or all buffer tanks).

**Unit:** Individual units can be defined within classes (e.g. one individual media tank). Each unit can feature specific tags and values for actors and sensors.

**Equipment Module:** Functionally associated groups of sensors, actors and controllers can be arranged into equipment modules (e.g. valve group of a tank).

**Control Module:** All actors (e.g. sampling valve) are represented in **FS INPUT®** as control modules. A variety of states can be defined (e.g. "delayed", "pulsing" etc.).

**Analog Value / Binary:** All sensors (analog values - e.g. temperature sensors / binary signals - e.g. level switches) are represented as "AV / Binaries" in **FS INPUT®**.

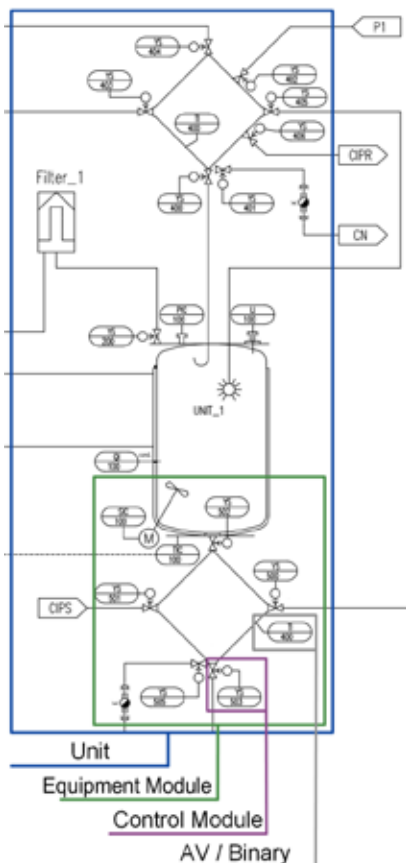

Create comprehensive functional specification documents with many features and details

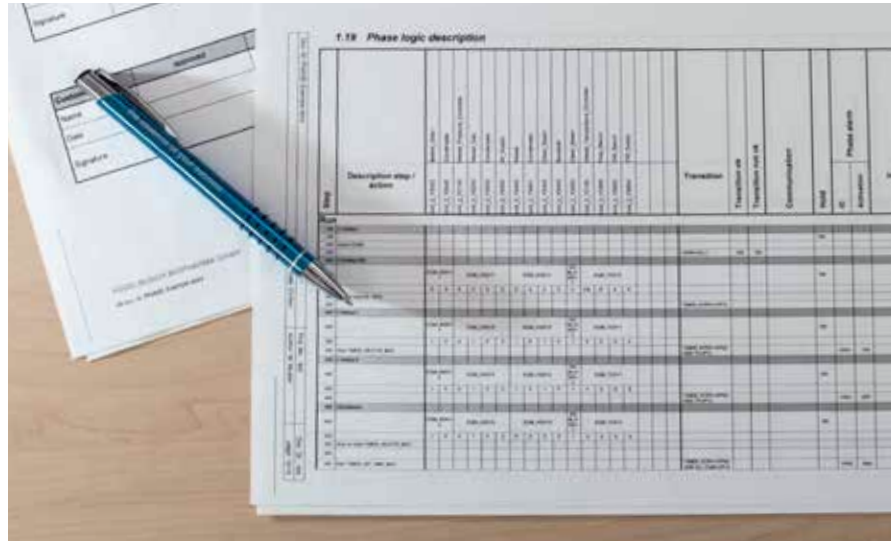

## Functional specifications in **FS INPUT®**

The main objective of **FS INPUT®** is providing functional specification documents for the automation of complex industrial systems. In **FS INPUT®** the functionalities are specified in so-called phases which contain all information about the individual process steps. In phases the definition of many features and details is possible in order to provide comprehensive functional specification documents:

- Step descriptions to specify process actions
- Transition conditions to define the logical sequence of steps
- Communication signals offer an interface with other classes and units
- Messages to the operator and their confirmation can be defined
- Alarms and locks ensure secure operation of the system
- Reports make sure that relevant measurements are stored
- Unit parameters to define equipment specific values
- Phase parameters to specify process specific (batch) values
- Pulsing, delayed or event triggered valves can be defined

Besides the logical description, the valve matrix is an essential part of a phase. In **FS INPUT®** valve settings for each individual process step are specified at equipment module level. **FS INPUT®** enables selection of previously defined valve settings during phase configuration in order to create a reliable valve matrix with minimum effort.



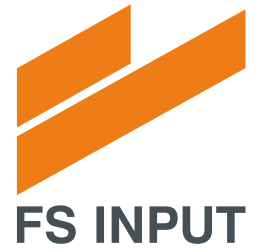

VOGELBUSCH BIOPHARMA GmbH  
Blechturmstraße 11 | 1050 Vienna | Austria  
T +43 1 54 661-0 | F +43 1 54 661-100  
fsinput@vogelbusch-biopharma.com  
fsinput.vogelbusch-biopharma.com

